

TYPHOON®

AIR RELEASE VALVES (AIR CUPS)

+Technical Specifications





We Care Every Drop of Water...

That is why our company, which has been developing products in the field of water systems for over 20 years, offers increasingly efficient solutions every day. With our expertise and experience, we continue to develop innovative technologies for the proper control and sustainable use of water.

OUR PRODUCTION CAPACITY IS INCREASING!
OUR GOALS ARE BIGGER!

We have been wherever there is water since 2004.

Founded in Izmir by Tayfun Yazarođlu, TAYFUR WATER SYSTEMS set out with the belief that water is the source of life. Beginning with the production of hydraulic control valves, this journey has now transformed into a strong and reliable brand offering innovative solutions across a wide range of areas, including irrigation, drinking water, firefighting and industrial systems.

In every project, while determining the direction of water, we are also shaping the sustainable infrastructure of the future. From production to project design, from installation to technical support, we work without compromising on high quality standards, with our state-of-the-art facilities and expert team. We aim to offer our customers not just products, but also trust, continuity and technical excellence.

TYPHOON branded products are developed entirely with our own production capabilities and local engineering expertise. These products stand out not only for their durability, but also for our philosophy of preserving the value of every drop. Thanks to our production processes that comply with international standards and our customer satisfaction-focused approach, we are proud to be recognised as a reliable business partner both domestically and globally.

Today, TAYFUR WATER SYSTEMS, a brand with roots in Izmir, continues on its path with the vision of being a symbol of quality, innovation, and trust wherever water is present.





Agricultural Irrigation Systems

The foundation of efficient agricultural production lies in delivering water at the right time, in the right quantity, and to the right location. Modern agricultural irrigation systems ensure both the efficient use of water resources and an increase in product quality and yield. The solutions developed in this context enable farmers to achieve a sustainable production structure independent of climatic conditions.

At TAYFUR WATER SYSTEMS, with our many years of engineering experience in the field of agricultural irrigation, we manufacture critical components such as hydraulic control valves, suction valves, backwash valves and meters to high quality standards. Each of our products saves energy by increasing the automation capabilities of the systems, prevents water wastage and minimises maintenance requirements. Thus, we offer reliable and long-lasting solutions for both small-scale businesses and large agricultural projects.

The products we develop are designed in accordance with international standards and tested to deliver maximum performance in challenging field conditions. At TAYFUR WATER SYSTEMS, our goal is to provide smart, durable, and sustainable systems for producers who value every drop. Because we believe that by determining the direction of water, we are shaping the future of agriculture.



Industrial Area Systems

Proper water management in industrial facilities is critical to the efficiency and sustainability of production processes. Every application, from pressurised lines to cooling circuits, fire systems to process lines, requires precise control and high durability. Therefore, the performance of equipment used in industrial systems is directly related to facility safety and operational continuity.

At TAYFUR WATER SYSTEMS, we manufacture products that play a critical role in industrial applications, such as hydraulic control valves, backwash valves, vacuum breakers, and meters, to high engineering standards. Our products adapt to harsh working conditions with their high pressure resistance, corrosion resistance, and long service life. By providing complete control over fluid management, they increase energy efficiency in systems and minimise maintenance times.

Designed to comply with international standards, our solutions are trusted across a wide range of applications, from factories to power plants, water treatment facilities to infrastructure projects. At TAYFUR WATER SYSTEMS, our goal is to make industrial water management smarter, safer and more sustainable, providing our customers with the assurance of uninterrupted operations.



Fire Systems

Fire safety is one of the most vital elements of every structure, from industrial facilities to public buildings, infrastructure projects to living spaces. The reliability of the equipment used in these systems is critical not only for the protection of the facility but also for the protection of human life.

As TAYFUR WATER SYSTEMS, we are a company specialising in the production of hydraulic control valves to ensure maximum safety in fire lines. Our products are designed to guarantee the fast, reliable and uninterrupted operation of fire systems. These valves, which stand out for their high pressure resistance, leak-proof performance and long service life, are tested in accordance with international standards and offered with quality assurance.

With our advanced engineering infrastructure and production experience, we produce solutions that can be used safely in various applications, from automatic sprinkler systems to fire pump stations. At TAYFUR WATER SYSTEMS, our goal is not just to manufacture products; it is to be part of systems that make a difference in fire safety, inspire confidence, and protect life.



Filter Automation

Water is a vital resource that must be managed with maximum efficiency during the filtration stage, as it is in many industrial and agricultural processes. Proper automation in filtration systems is critical in terms of energy savings, ease of maintenance, and system continuity. An effective filter automation system determines not only the quality of the water but also the lifespan and efficiency of the entire system.

At TAYFUR WATER SYSTEMS, we offer comprehensive solutions in the field of filter automation. Our products, such as hydraulic control valves, backwash valves and panels, bottom valves, and dirt traps, ensure precise flow management in automatic filter systems. Our products optimise the water filtration process while performing backwashing operations precisely and efficiently. This reduces the risk of clogging in systems, prevents energy losses, and extends maintenance intervals.

All our products stand out with their durable material construction, precise control capability, and long-lasting design. At TAYFUR WATER SYSTEMS, our goal is to provide our customers with smart, reliable, and sustainable automation solutions by maximising efficiency in filtration processes. Because we believe that water purity begins with system safety.

Air Release Valves (Air Cups)

Plastic / Brass

Air Release Valves (Air Relief Valves) are equipment designed to control the air-water balance in pressurized water systems, playing a critical role in system safety and efficiency. Air accumulation or vacuum effects that may occur in pipelines can negatively affect water flow, causing pressure fluctuations, flow losses, and even line deformations. Air Release Valves eliminate these risks, ensuring stable, quiet, and efficient system operation.

During pipeline filling, air release valves quickly release air from the pipeline, ensuring uninterrupted and smooth water flow. During operation, they release small air bubbles that accumulate within the pipeline under controlled pressure, maintaining a uniform water flow. They admit air into the system to prevent vacuum effects that may occur during pipeline emptying and balance the internal pressure with atmospheric pressure, preventing potential hazards such as cavitation, pipe collapse, and equipment damage.

Thanks to their durable body structure, high-performance internal mechanism, and easy maintenance, air Release Valves: They can be safely used in many different applications, including agricultural irrigation, drinking water networks, industrial facilities, and pumping stations.

Vacuum cups are manufactured in three different types depending on their intended use:

Single-Acting (Kinetic) Plastic Air Suction Cups – Available in ½", ¾", 1", and 2" sizes; used for high-volume air removal during line filling and emptying.

Double-Acting (Automatic) Plastic Air Suction Cups – Available in ½", ¾", and 1" sizes; provide continuous removal of small air masses under pressure during operation.

Triple-Acting (Combination) Plastic Air Suction Cups – Available in 2" sizes; combine both large-volume air removal and the removal of small air accumulations that occur during operation in a single body

Providing high performance, long life and complete sealing, Suction Cups are an integral part of engineering solutions that aim for maximum efficiency and safety in water systems.



®
TAYFUR
HOON
TYP

Places of Use For Air Release Valves

Air release valves are widely used in agricultural irrigation, filtration systems and industrial installations for air evacuation and vacuum prevention in water systems.

- In agricultural irrigation systems: It should be used at pump outlets, every 400–500 meters on the main line, at the beginning of slopes, at the peaks of upward slopes, at the ends of lines, and before irrigation valves.
- In filtration systems: It ensures safe system operation in equipment such as disc filters, hydrocyclones, gravel tanks, and automatic horizontal filters.
- In industrial and treatment facilities: It is used for air removal and pressure balancing in in-plant water lines, treatment systems, and similar applications.

These usage points ensure that the line operates continuously, efficiently, stably and safely.

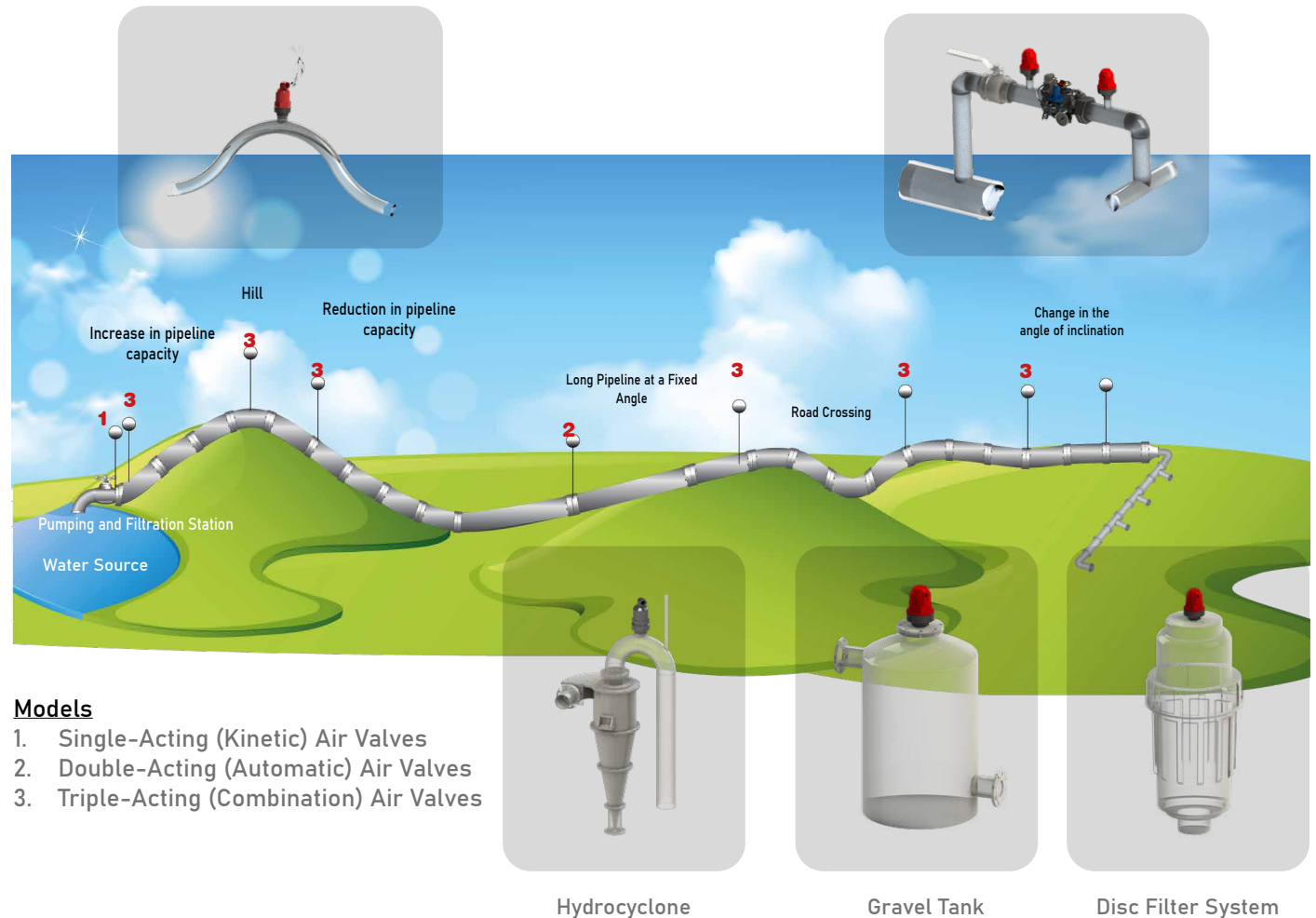

1/2" - 3/4" - 1" Double Action (Automatic) Air Valve

Main Components

#	Material Name	Material Type
1	Body	Glass Reinforced Polyamide
2	O-Ring	NBR
3	Float	polypropylene
4	Cover	Glass Reinforced Polyamide
5	Float Rubber	EPDM

#	Unit	1/2"	3/4"	1"
H	Height (mm)	112	112,75	136,57
W	Width (mm)	58,88	58,88	85,65
D	Connection Diameter	1/2"BSP	3/4"BSP	1"BSP
A	Nozzle Area	25mm ²	25mm ²	25mm ²
-	Weight (kg)	0,140	0,141	0,304

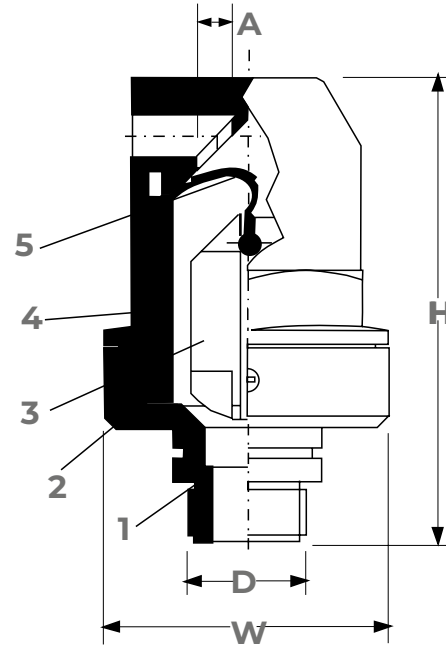

2" Triple-Effect (Combination) Air Valve

Main Components

#	Material Name	Material Type
1	Body	Glass Reinforced Polyamide
2	O-Ring	NBR
3	Cover	Glass Reinforced Polyamide
4	Float	Polypropylene
5	Fork Rubber	EPDM
6	Float Fork	Glass Reinforced Polyamide
7	Float Seal	EPDM

#	Unit	2"
H	Height (mm)	243
W	Width (mm)	103
D	Connection	2" BSP
a	Automatic Nozzle Area	7mm ²
-	Weight (kg)	0,695
A	Kinetic Nozzle Area	855mm ²

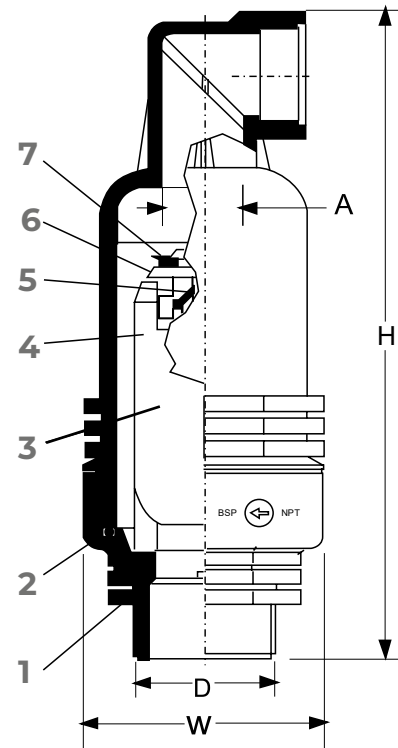

Discharge Mode

Open position

It ensures that the large amount of air in the pipeline is rapidly evacuated from the system during its initial start-up.

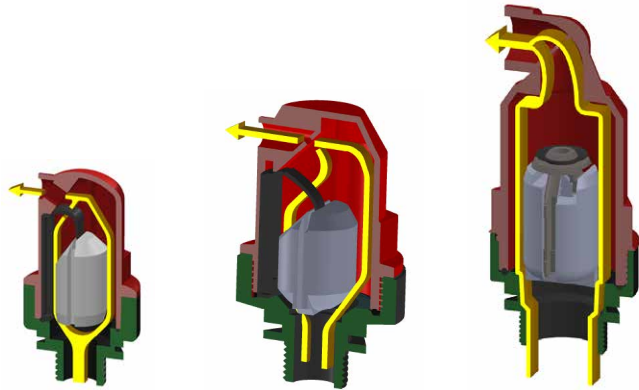

Closed Position

When the water reaches the suction cup, the float rises and closes the suction cup outlet.

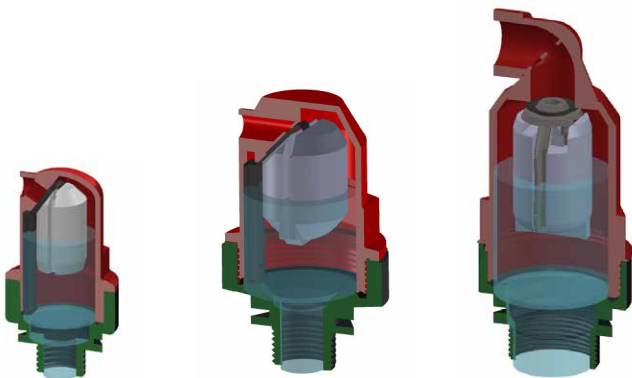

Pressure Balancing Mode

Open position

During the withdrawal or discharge of water from the pipeline, the pressure in the pipeline becomes lower than atmospheric pressure. This situation, known as the vacuum effect, causes collapse and cavitation damage in the pipes. The float valve descends (open position) and prevents this problem by allowing air to flow into the pipeline from outside.

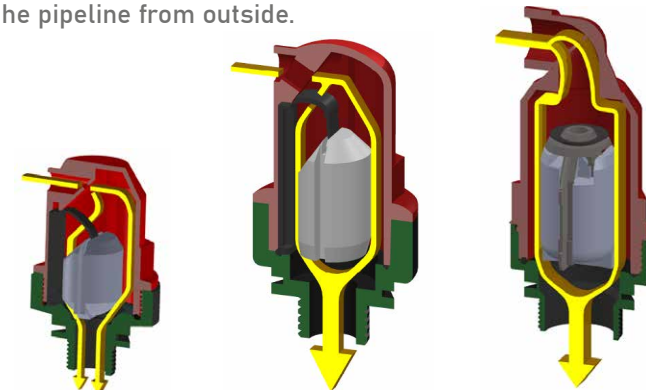

Closed Position

During system servicing, i.e. when the pipeline is under pressure, a small amount of air is carried along with the water and collects in specific areas such as the higher sections of the pipeline. The accumulated pressurised air is discharged together with the water, partially raising the float (modulation position). After discharge, the float rises again and closes the suction outlet (closed position).

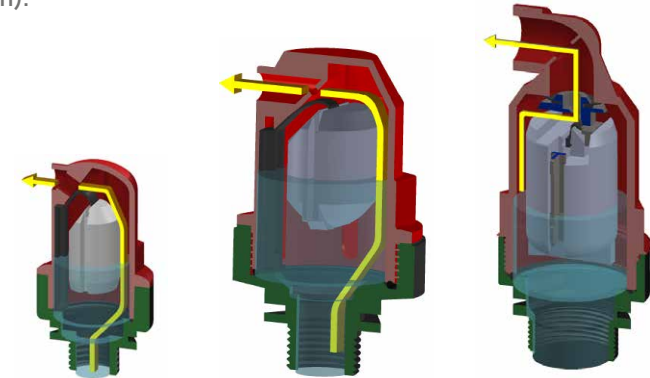

1/2" - 3/4" - 1" Double Action (Automatic) Air Valve

Air inlet

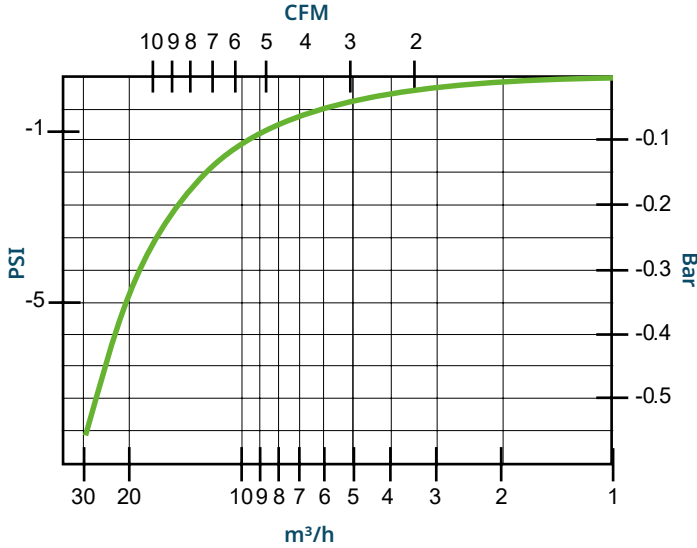

Air Ventilation

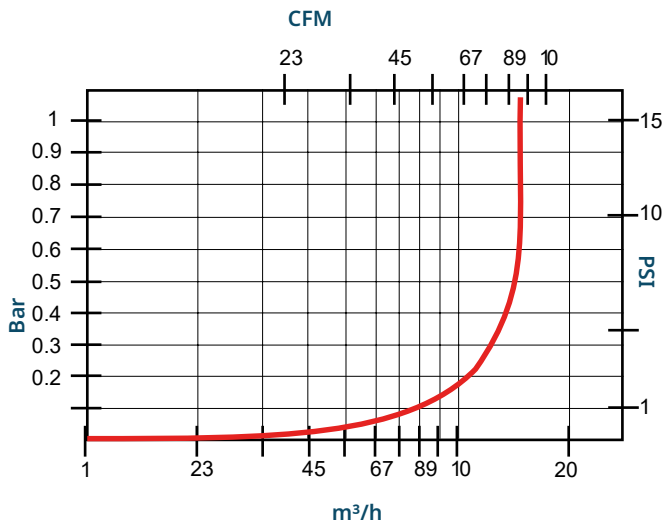

2" Triple-Effect (Combination) Air Valve

Air inlet

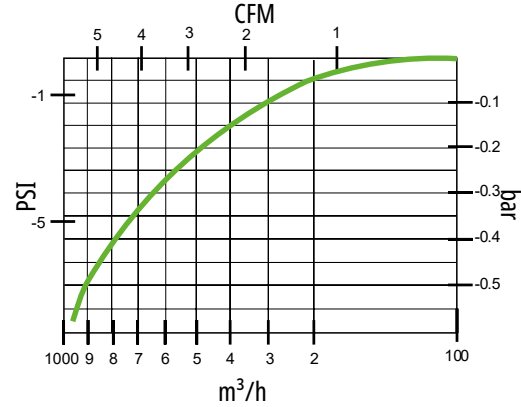

Air Ventilation

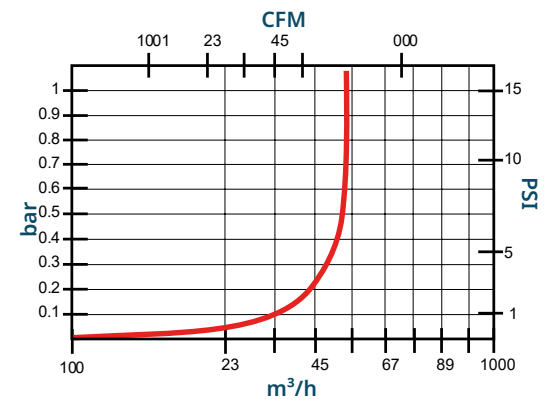

Air Release - Automatic Valve

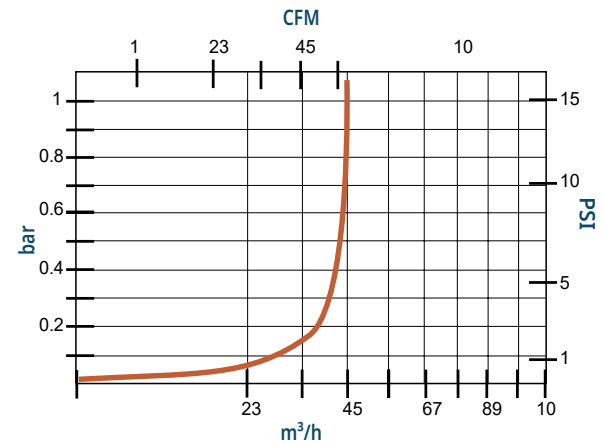

1/2" - 3/4" - 1" Single-Effect (Kinetic) Air Valve

Main Components

#	Material Name	Material Type
1	Body	Glass Reinforced Polyamide
2	O-Ring	NBR
3	Float	Polypropylene
4	Cover	Glass Reinforced Polyamide
5	Float Rubber	EPDM

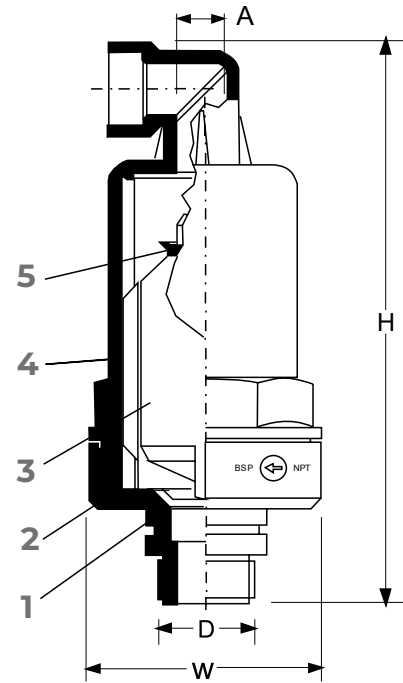

#	Unit	1/2"	3/4"	1"
H	Height (mm)	111,98	112,12	191,60
W	Width (mm)	58,88	58,88	85,65
D	Connection	1/2"BSP	3/4"BSP	1"BSP
A	Nozzle Area	314 mm ²	314 mm ²	314 mm ²
-	Weight (kg)	0,138	0,141	0,364

2" Single-Effect (Kinetic) Air Valve

Main Components

#	Material Name	Material Type
1	Body	Glass Reinforced Polyamide
2	O-Ring	NBR
3	Float	Polypropylene
4	Cover	Glass Reinforced Polyamide
5	Float Rubber	EPDM

#	Unit	2"
H	Height (mm)	243
W	Width (mm)	103
D	Connection	2" BSP
A	Nozzle Area	855 mm ²
-	Weight (kg)	0,672

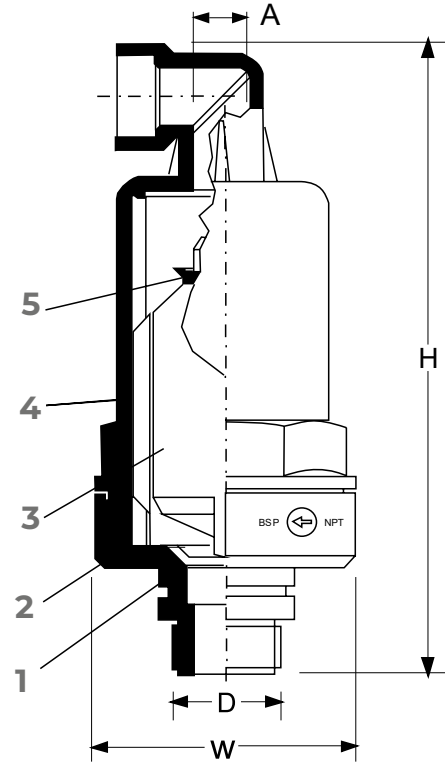

Discharge Mode

Open Position

It ensures that the large amount of air in the pipeline is rapidly evacuated from the system during its initial start-up.

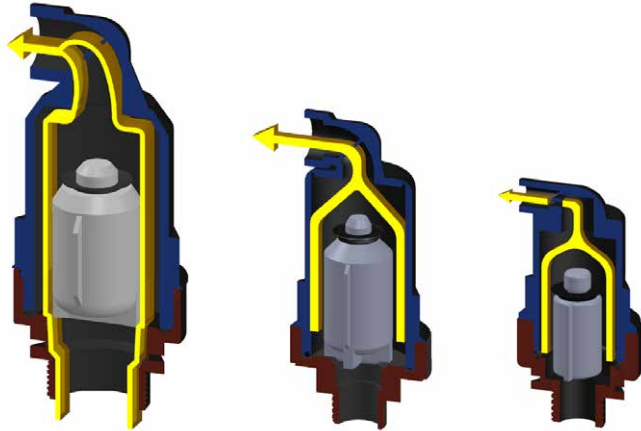

Closed Position

When the water reaches the suction cup, the float rises and closes the suction cup outlet.

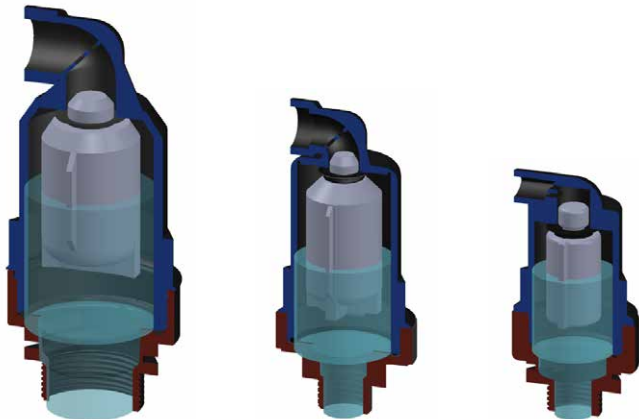

Pressure Balancing Mode

Open Position

During the withdrawal or discharge of water from the pipeline, the pressure in the pipeline becomes lower than atmospheric pressure. This situation, known as the vacuum effect, causes collapse and cavitation damage in the pipes. The float valve descends (open position) and prevents this problem by allowing air to flow into the pipeline from outside.

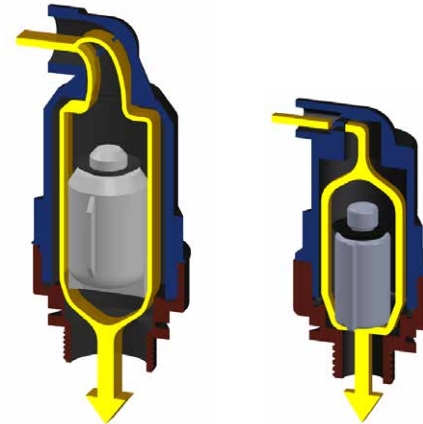

Plastic Sewage Air Release Valves

The Plastic Wastewater Suction Cup is a special hydraulic suction cup designed to safely and effectively perform air evacuation and air suction functions in sewer and wastewater systems. It quickly and controlledly releases air accumulated during pipeline filling, preventing vacuum buildup during line emptying or when the water level drops, protecting pipelines from damage such as collapse and cavitation.

This suction cup is designed for use in wastewater and wastewater lines. It provides reliable air management, particularly in sewer networks, treatment plants, industrial wastewater systems, and filtration lines. Its double-action float mechanism discharges pressurized air within the line and prevents the accumulation of small air bubbles, thus maintaining the system's hydraulic balance.

The Plastic Wastewater Suction Cup is optimized for corrosive and particle-containing environments. The durable and stainless construction of its body and moving parts ensures long life. The ball valve on the unit allows for easy cleaning and maintenance. Its shock-free and leak-proof operation ensures continuous, safe, efficient, and trouble-free system operation.

Models

- 1" automatic (double-action) wastewater suction cup
- 2" combination (triple-action) wastewater suction cup
- 2" kinetic (single-action) wastewater suction cup



®
TAYFUR
HOOON
TYP HOOON

Main Components

#	Material Name	Material Type
1	Plastic Combination / Automatic Air Release Valve	Plastic
2	Stem	Stainless Steel
3	Float Valve	Polypropylene
4	Cover	GRP
5	Mini Ball Valve	Galvanized

Dimensions

Model	D (mm)		W (mm)		H (mm)	
	inch	mm	inch	mm	inch	mm
2" Combination (3 Functions)	2"	50	5,12	130	14,17	360
2" Automatic (2 Functions)	2"	50	5,12	130	9,84	250

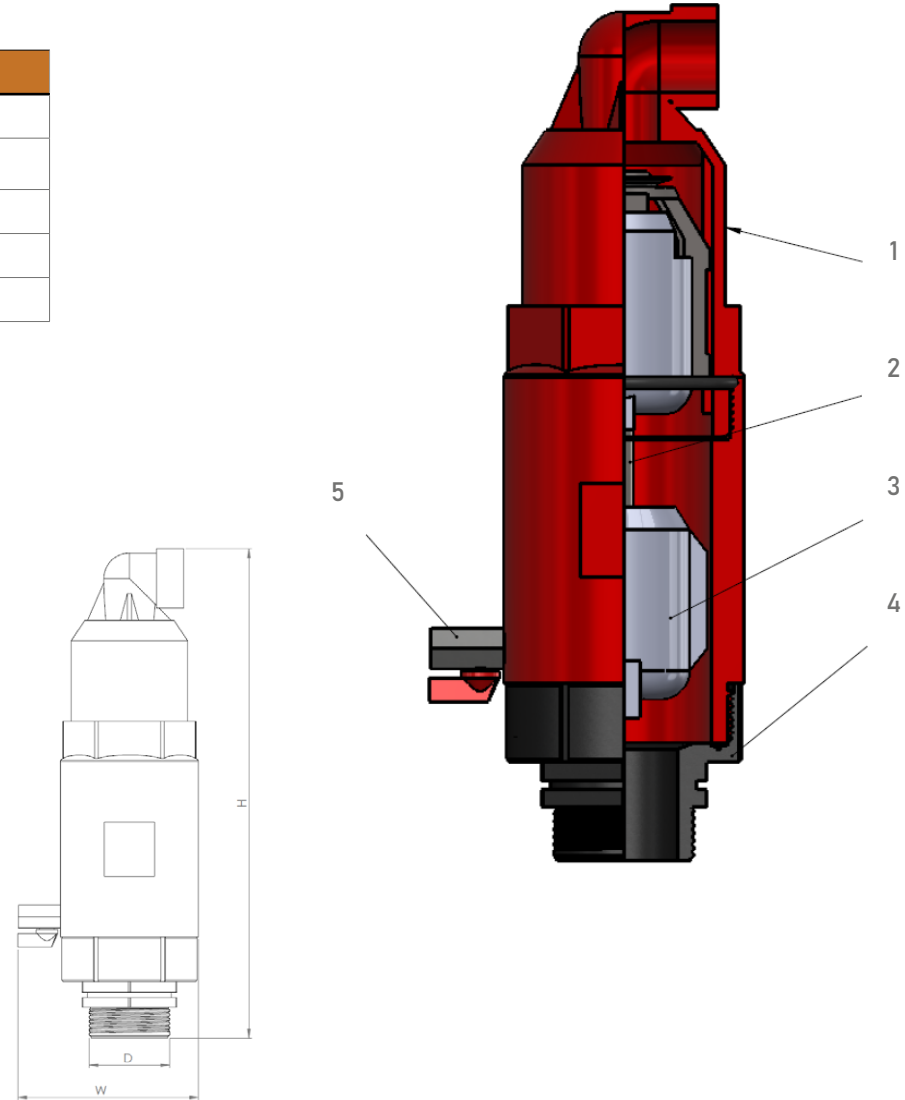

Trade Fairs





Kemalpaşa OSB Mahallesi Kuzey Sanayi Caddesi
Dış Kapı No:13
Kemalpaşa / İzmir

+90 232 458 49 99
+90 232 458 57 67

TYPHOON®

www.tayfursu.com.tr | info@tayfursu.com.tr

Her
Fabrika
Bir
Kaledir*

H. Atatürk



* Every factory is a fortress